



ELFOEnergy Medium

AIR COOLED WATER CHILLER FOR OUTDOOR INSTALLATION



Reduced energy consumption
Optimised operation at partial loads
Complete hydronic assembly supplied as standard
Direct FREE-COOLING

WSAT-XEE 82 - 302 (R-410A)

Size	Cooling [kW]
82	24,3
102	28,2
122	33,7
162	40,0
182	45,9
222	54,4
262	64,1
302	72,2

REPLACE: BT07F014GB-08

The ELFOENERGY series chillers represent an important stage in the development of this type of unit. They feature the most up-to-date advances in technology, standing out for:

EFFICIENCY

thanks to its special construction, the ELFOENERGY ensures high energy efficiency, in particular during operation at partial loads;

SELF-ADAPTING

the evolved electronics implemented adapt the operating parameters of the chiller to the load conditions of the system it is installed in, optimising consumption, efficiency and the working life of the components;

EASE OF INSTALLATION

each unit is supplied as standard with a complete hydronic assembly and is completely tested in the factory; installation is consequently quick and easy.

BT07F014GB-09



Clivet is participating in the EUROVENT Certification Programme. Products are listed in the EUROVENT Directory of Certified Products and in the site www.eurovent-certification.com. Eurovent Chillers Certification Programme covers air cooled packaged chillers up to 600 kW and water cooled packaged chillers up to 1500 kW.

CERTIFIED QUALITY SYSTEM UNI EN ISO 9001:2008

COMFORT IS A HUMAN RIGHT. CARE FOR THE ENVIRONMENT IS A HUMAN DUTY.

The ELFOENERGY is an appliance of new conception, designed especially to operate with increasing efficiency as thermal load reduces, yet able to handle the maximum load demand whenever necessary. Because of significant diurnal and seasonal variations in load, chillers must operate for prolonged periods under partial load conditions. A ELFOENERGY unit always ensures conditions of maximum comfort coupled with ultra high efficiency for most of the system's working life, which means a big saving in electrical energy. This reflects the corporate policy of CLIVET, namely: offering fundamental and concrete solutions to help safeguard the well-being of people and their environment. By way of example, here is a seasonal thermal load graph relating to a multi-use building (shops, offices and apartments) located in the Milan area.

SEASONAL THERMAL LOAD

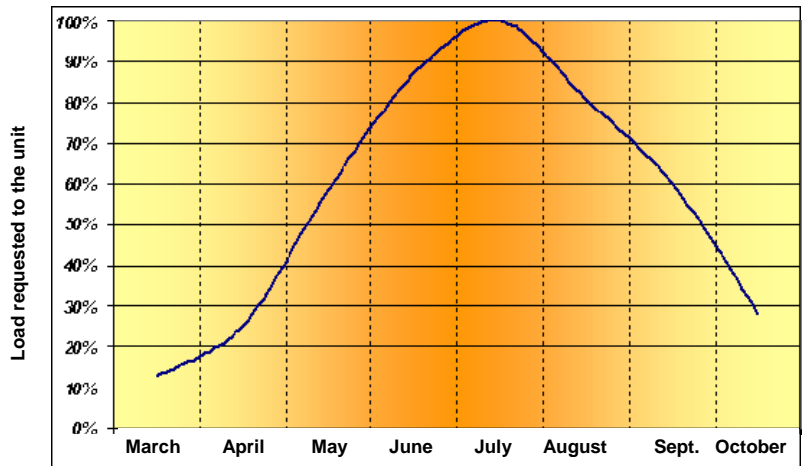

MULTIPLE HIGH EFFICIENCY SCROLL COMPRESSORS IN THE SAME COOLING CIRCUIT

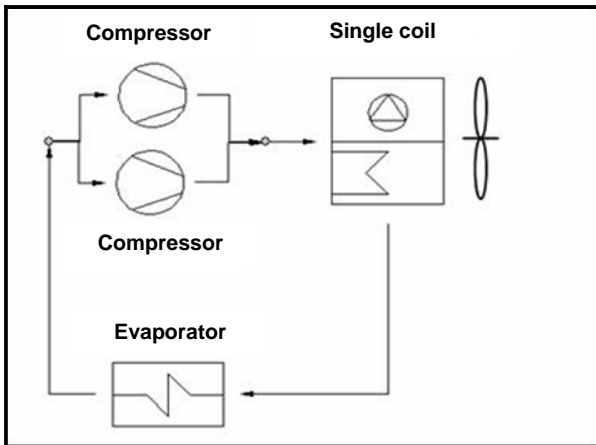

A key aspect of the approach adopted in designing the ELFOENERGY is the notion of equipping a single cooling circuit with a battery of SCROLL compressors, rather than the conventional separated circuit. Moreover the use of compressors with different capacities allows a rise of the capacity step number and in this way a better capacity-control flexibility. This enables the unit to adapt perfectly to the system load. The evolved control equipment used with ELFOENERGY units will optimize the activation sequence and balance the operating cycles of the compressors to maximum advantage.

HIGH EFFICIENCY AT PARTIAL LOADS

The unit in an air-conditioning system is selected on the basis of the maximum load the system is designed to handle. In practice however, maximum load conditions account only for a small percentage of the overall operating time, whereas the partial load operation is the true condition in which the unit had to operate. Simulation tests conducted in different buildings have shown that systems operate on average for 90% of total operating time with thermal load lower than 60%. Accordingly, operating efficiency under partial load conditions is a key consideration when selecting a chiller.

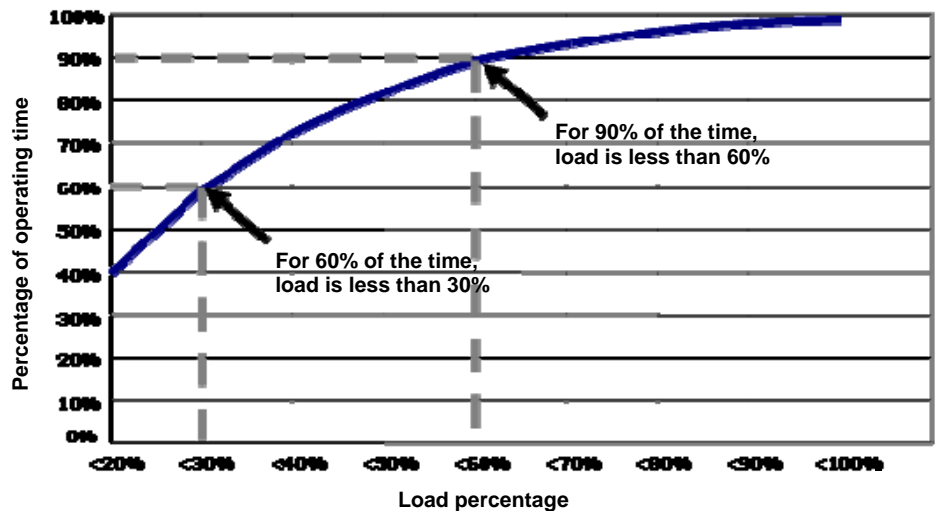

E107F01NCE09

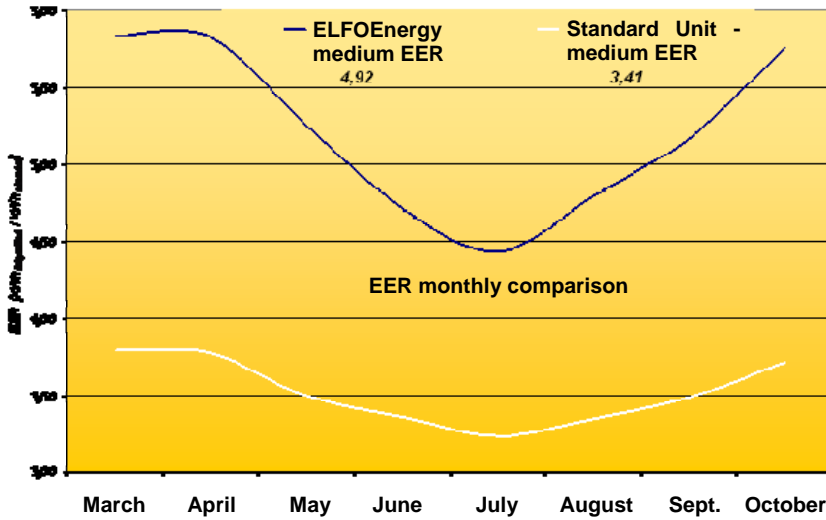

The electronic controller and the specific constructional configuration highlight the thermodynamic efficiency of ELFOENERGY. To achieve maximum efficiency, the electronic controller starts the compressors according to the most favourable ratio between the exchange surfaces, so that the condensing and evaporation temperature are always the most advantageous. The diagram to the side shows the trend in efficiency (EER) of an ELFOENERGY unit and of a traditional unit on a typical summer day. It is clear how the efficiency of the ELFOENERGY is practically always higher, reaching values that are even more than twice as high at some times of the day, when the load thermal is lower.

LOW OPERATING COSTS

Thanks to the characteristics described previously, ELFOENERGY ensures much higher efficiency than a traditional chiller for most of the operating time. Comparing, in the same system, the power consumption of the ELFOENERGY against the power consumption of a traditional chiller with the same capacity, the seasonal savings can reach around 35%. These data, combined with the intrinsic reliability of the unit, make the ELFOENERGY an essential option in both terms of pay back time and peace of mind.

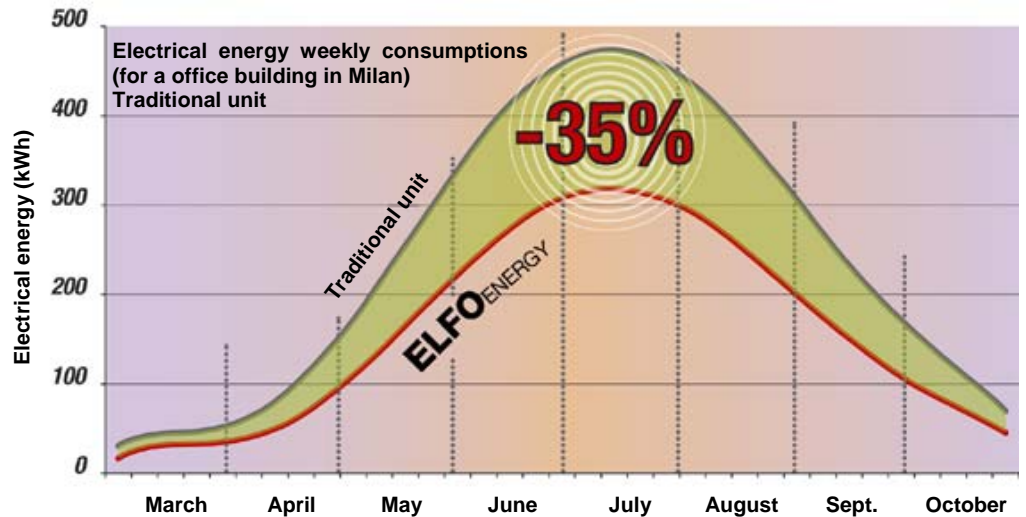

In a system with a 34 kW unit installed, the annual energy saving obtained with a ELFOENERGY is in the region of 3.000 kWh, which signifies a cost saving of €500 and 590 kg less fuel to transport and burn.



NOISE TOO IS LOAD-DEPENDENT

The condenser electronic controller, fitted as standard on all the ELFOENERGY units, automatically adjusts the fan speed as the thermal load decreases. As the fans are the greatest source of noise for this type of unit, it is clear how this feature brings important benefits, in particular at night, when the load is reduced but noise sensitivity is heightened.

E107F014CE809

GLIDING TEMPERATURE

The ELFOENERGY electronic control permits the adjustment of the supply temperature of the water generated by the unit to the load conditions which are detected by the unit. This function is called GLIDING TEMPERATURE a concept by which the unit is continuously hunting for the best balance between the supplied capacity and the energy spent to produce it.

ALL-IN-ONE PHILOSOPHY

ELFOEnergy is a unit "ready for use", including not only the components of the refrigerant circuit, but also a water circuit complete with pump (optional double pump), safety valve, filling assembly and filter. As a result, the only requirement is to connect the unit to the water inlet and outlet pipes; in this way, the commissioning times and the possible problems during installation are reduced to the minimum.

Controls keyboard



WATER FILTER

Water filter (external installation)

steel mesh mechanical filter positioned at the exchanger inlet. Suitable for filtering water and trapping the impurities present in the water circuit. Mechanic steal-mesh filter is supplied standard on units with hydronic kit



N° 1 PUMP with standard, reduced or larger discharge head



STANDARD UNIT SPECIFICATIONS**COMPRESSOR**

Hermetic orbiting scroll compressor complete with motor over-temperature and over-current devices and protection against excessive gas discharge temperature. Fitted on rubber antivibration mounts and complete with oil Charge. An oil heater is automatically switched on at the compressor shut-down to prevent oil dilution by the refrigerant.

STRUCTURE

Structure made from zinc-magnesium plate, providing excellent mechanical characteristics and extensive corrosion strength

PANELLING

External panels in prepainted zinc-magnesium especially indicated in outdoor installation due to its superior resistance to corrosion avoiding periodic painting. Side panels are easily removable and allow complete access to unit components. Internal sound proof lining reduces sound pressure levels.

INTERNAL EXCHANGER

Direct expansion heat exchanger, braze-welded AISI 316 stainless steel plates with large exchange surface and complete with external heat and anti-condensate insulation.

The exchanger comes complete with:

- differential pressure switch, water side antifreeze heater to protect the water side exchanger, preventing the formation of frost if the water temperature falls below a set value.

EXTERNAL EXCHANGER

Heat exchange coil with aluminium fins and copper tubes in staggered rows. The coils are complete with integral subcooling circuit which assures the correct refrigerant feeding of the expansion valve. Available in different options as per optional list.

FAN

82-122 Low speed axial fan directly driven by single phase external rotor motor with incorporated thermal overload.

162-302 Low speed axial fan directly driven by three-phase external rotor motor with incorporated thermal overload.

Housed in aerodynamically shaped enclosures to increase the efficiency and reduce the noise level. Complete with fan guard in order to help against fortuitous contact with the blades.

REFRIGERANT CIRCUIT

The circuit is complete with:

- filter dryer
- sight glass with moisture indicator
- high pressure switch
- low pressure switch
- liquid receiver
- compressor suction shut-off valve
- compressor discharge shut-off valve
- high pressure safety
- thermostatic expansion valve with equalizer
- pressure probes

ELECTRICAL PANEL

The Power Section includes:

- isolating transformer for auxiliary circuit power supply
- main line isolator switch
- compressor overload cutout switch
- fan fuses
- centrifugal pump motor protector
- compressor control contactor
- pump control contactor

- phase cutting fan speed controller (pressure)

The control section includes:

- display of the set values and the error codes
- H2o antifreeze and high refrigerant gas pressure pre-alarm function that reduces cooling capacity to avoid unit shut-down
- compressor overload protection and timer
- antifreeze protection
- Compressor timer / operation signal LED
- possibility of communication with ZONE MASTER system (optional)
- proportional + integral water temperature control
- relay for remote cumulative fault signal
- self-diagnosis system with immediate display of the error code
- ON/OFF and alarm reset buttons
- UP and DOWN buttons to increase and decrease the values
- display of the set values, the error codes and the parameter index
- compressor operating hour display
- remote ON/OFF control
- water pump control
- function and command buttons
- set point compensation with 4-20 mA signal

HYDRAULIC CIRCUIT

- water side safety valve
- impurity trap with filter
- Centrifugal pump
- antifreeze heater protection to pumping station
- drain valve
- Closed couple pumps with high efficiency impellers. Maximum operating pressure 1000 kPa. Temperature range from -10 to +80° C. Maximum glycol concentration 40%. Motor: closed type. External ventilation. Protection IP55. Insulation class F. Clockwise rotation looking at the pump from the motor side.

ACCESSORIES

- stainless steel mesh mechanical filter (to be used, if required, with unit configured without hydronic group)
- finned coil protection grill.
- serial communication module to supervisor (MODBUS)
- set point compensation according to the outside enthalpy
- daily and weekly programming clock
- set point compensation with outside temperature probe
- high and low pressure gauges
- control keypad for remote installation that repeats all the functions already present on the onboard microprocessor control.
- Phase monitor
- Rubber antivibration mounts

CONFIGURATION CODE

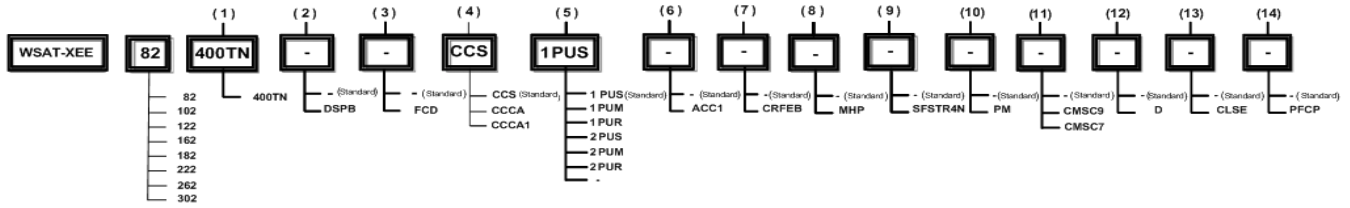

(1) VOLTAGE

Supply voltage 400/3/50+N(400TN)

(2) DOUBLE SET POINT

Double set point for water low temperature(DSPB)
double set point with units in "Brine" version

(3) FREE COOLING

Free-cooling: not required(-)
standard
direct FREE-COOLING(FCD)

(4) CONDENSING COIL

Standard condenser coil(CCS)
standard
Copper / aluminium condenser coil with acrylic lining(CCCA)
Copper / aluminium condenser coil with Fin Guard treatment (Silver) (CCCA1)

(5) HYDRONIC GROUP UTILITY SIDE

Standard pump(1PUS)
Standard
Single-pump with larger available head(1PUM)
Single-pump with reduced available head(1PUR)
Standard double pump(2PUS)
Double pump with larger available head(2PUM)
Double pump with reduced available head(2PUR)
Not available for 82-102-122 size
Hydronic group utility side: not required(-)

(6) STORAGE TANK

Storage tank: not required(-)
standard
Teflon steel storage device(ACC1)

(7) EXTERNAL SECTION FAN CONSUMPTION REDUCTION

Device for fan consumption reduction of the external section: not required(-)
standard
Device for reduction of fan consumption ECOBREEZE(CRFEB)

(8) PRESSURE GAUGE

High and low pressure gauges: not required(-)
Standard
High and low pressure gauges (MHP)

(9) SOFT STARTER

Disposal for inrush current reduction: not required (-)
Standard
Disposal for inrush current reduction, for unit 400/3/50+N(SFSTR4N)

(10) PHASE MONITOR

Phase monitor: not required(-)
Standard
Phase monitor (PM)

(11) SERIAL COMMUNICATION MODULE

Serial communication module: not required (-)
Standard
Serial communication module to supervisor (Modbus) (CMSC9)
Modbus/LON WORKS serial converter kit (CMSC7)

(12) ENERGY RECOVERY

Energy recovery: not required(-)
Standard
Partial energy recovery(D)

(13) ADDITIONAL FREE CONTACTS

Additional free contacts: not required(-)
Standard
Free contacts for alarm(CLSE)

(14) POWER FACTOR CORRECTION CAPACITORS (COSFI > 0.9)

Power factor correction capacitors: not required(-)
Standard
power factor correction capacitors (cosfi > 0.9)(PFCP)

SOUND LEVELS

Size	Sound Power Level (dB)								Sound pressure level dB(A)	Sound power level dB(A)
	Octave band (Hz)									
	63	125	250	500	1000	2000	4000	8000		
82	80	75	78	73	70	66	58	52	60	75
102	79	74	77	73	70	66	60	51	60	75
122	79	74	77	72	70	67	61	52	60	75
162	89	82	78	80	77	69	64	59	64	81
182	89	82	77	79	77	71	66	60	64	81
222	89	82	80	81	77	72	64	59	65	82
262	89	82	79	80	78	73	67	59	65	82
302	89	82	80	81	78	73	64	57	65	82

Measures according to ISO 9614-2 regulations, with respect to the EUROVENT 8/1 certification.

The sound levels refer to the unit at full load, in the rated test conditions. The sound pressure level refers to a distance of 1m from the external surface of the units operating in an open field.

data referred to the following conditions :
- internal exchanger water = 12/7°C
- outdoor air temperature 35°C

INTERNAL EXCHANGER PRESSURE DROP

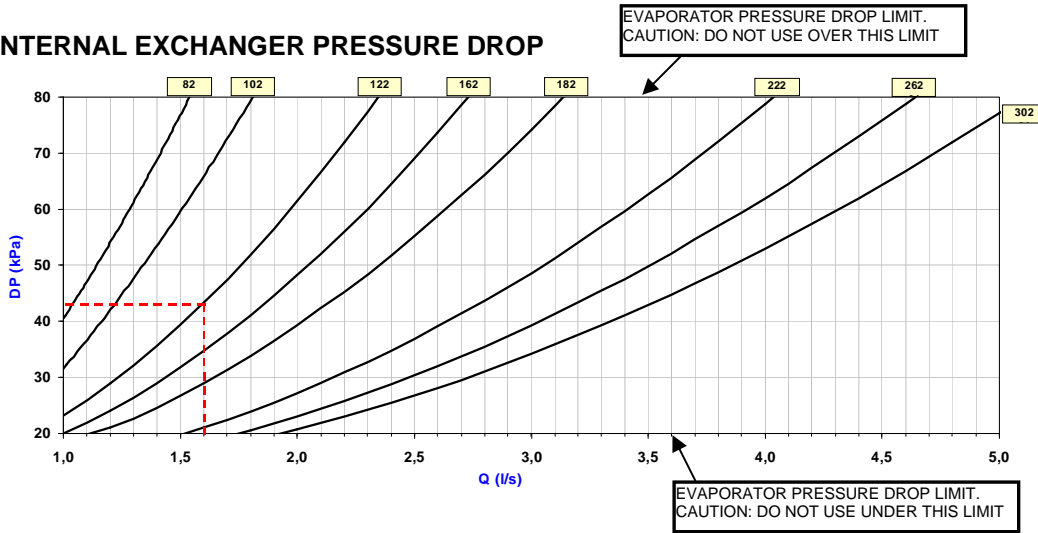

UNIT WITHOUT HYDRAULIC CIRCUIT COMPONENTS
Q = WATER FLOW
DP = PRESSURE DROP

Size	82	102	122	162	182	222	262	302
Minimum flow [l/s]	0.70	0.80	0.85	1.00	1.11	1.51	1.74	1.95
Maximum flow [l/s]	1.52	1.80	2.85	2.71	3.05	4.05	4.65	5.00

CURVE OF DISCHARGE HEAD WITH STANDARD PUMP (PUMP + WATER FILTER)

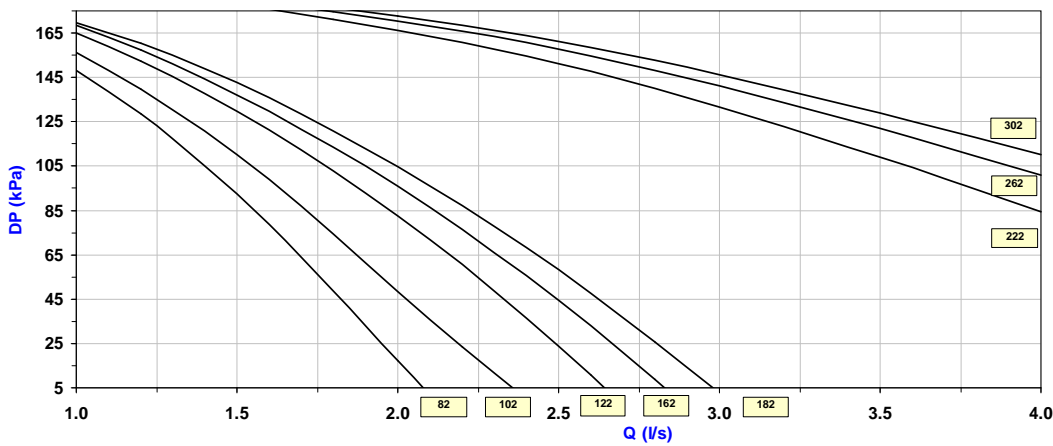

THE HEADS ARE INTENDED AS AVAILABLE AT THE UNIT CONNECTIONS
Q[L/S]= WATER-FLOW RATE
DP[KPA]=USEFUL DISCHARGE HEAD

CURVE OF DISCHARGE HEAD OF FREE-COOLING UNIT

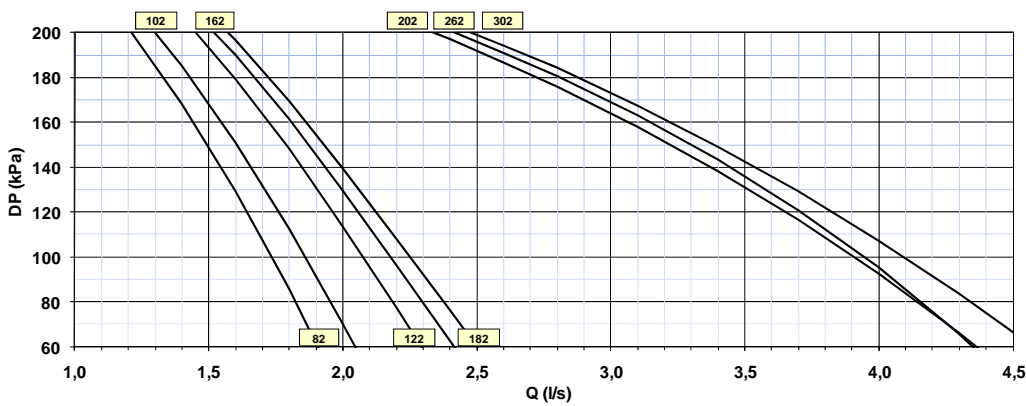

THE HEADS ARE INTENDED AS AVAILABLE AT THE UNIT CONNECTIONS
Q[L/S]= WATER-FLOW RATE
DP[KPA]=USEFUL DISCHARGE HEAD

B107F014CB09

GENERAL TECHNICAL SPECIFICATIONS

Size	82	102	122	162	182	222	262	302
------	----	-----	-----	-----	-----	-----	-----	-----

COOLING

Cooling capacity	1	kW	24,3	28,2	33,7	40	45,9	54,4	64,1	72,2
Compressor power input	1	kW	8,5	10	12,1	13,5	16	19,4	22,3	25,5
Total power input	2	kW	9,06	10,5	12,61	15,2	17,7	21,1	24,1	27,3
EER	3		2,68	2,68	2,67	2,62	2,59	2,57	2,66	2,64
ESEER (EN 14511:21012)			3,63	3,63	3,62	3,46	3,42	3,40	3,72	3,70

COMPRESSOR

Type of compressors	4		SCROLL	SCROLL	SCROLL	SCROLL	SCROLL	SCROLL	SCROLL	SCROLL
No. of Compressors		Nr	2	2	2	2	2	2	2	2
Std Capacity control steps		Nr	3	3	2	3	3	3	3	2
Oil charge (C1)		l	3,61	3,72	3,54	5,76	5,76	6,65	7,39	8,28
Refrigerant charge (C1)		kg	8,2	8	11	12	12,5	15,5	17,5	17,5
Refrigerant circuits		Nr	1	1	1	1	1	1	1	1

INTERNAL EXCHANGER

Type of internal exchanger	5		PHE	PHE	PHE	PHE	PHE	PHE	PHE	PHE
No. of internal exchangers		Nr	1	1	1	1	1	1	1	1
Water flow rate (Internal Exchanger)	1	l/s	1,2	1,3	1,6	1,9	2,2	2,6	3,1	3,4
Max water flow-rate		l/s	1,5	1,8	2,3	2,7	3,1	4	4,6	5,4
internal exchanger pressure drop		kPa	48	47	41	43	43	38	40	42
Useful pump discharge head	1	kPa	132	126	120	104	88	148	139	131

EXTERNAL SECTION FANS

Type of fans	6		AX	AX	AX	AX	AX	AX	AX	AX
Number of fans		Nr	2	2	2	1	1	1	2	2
Standard air flow	1	l/s	2545	2538	2514	4933	4875	4778	7196	7145
Installed unit power		kW	0,27	0,27	0,27	1,94	1,94	1,94	2,06	2,06

CONNECTIONS

Water fittings			1" 1/4	1" 1/4	1" 1/4	2"	2"	2"	2"	2"
----------------	--	--	--------	--------	--------	----	----	----	----	----

HYDRAULIC CIRCUIT

Max water side pressure		MPa	0,55	0,55	0,55	0,55	0,55	0,55	0,55	0,55
Safety valve calibration		kPa	600	600	600	600	600	600	600	600

POWER SUPPLY

Standard power supply		V	400/3/50+	400/3/50+	400/3/50+	400/3/50+	400/3/50+	400/3/50+	400/3/50+	400/3/50+
-----------------------	--	---	-----------	-----------	-----------	-----------	-----------	-----------	-----------	-----------

NOISE LEVELS

Sound pressure level (1 m)		dB(A)	60	60	60	64	64	65	65	65
----------------------------	--	-------	----	----	----	----	----	----	----	----

DIMENSIONS

Length		mm	1771	1771	1771	2012	2012	2012	2406	2406
Depth		mm	680	680	680	1100	1100	1100	1100	1100
Height		mm	1287	1287	1287	1599	1599	1599	1593	1593
Packing volume		m3	1,8	1,8	1,8	4	4	4	4,5	4,5

STANDARD UNIT WEIGHTS

Shipping weight		kg	304	309	328	464	476	497	556	569
Operating weight		kg	298	303	323	456	469	490	547	561

(1) data referred to the following conditions :

internal exchanger water = 12/7°C

external exchanger air intake 35°C

(2) Total absorbed power is given by the compressor absorbed power + fan absorbed power + auxiliary circuit absorbed power.

(3) 100% EER

data referred to the following conditions :

internal exchanger water outlet temperature = 7°C

room temperature = 35°C

(4) SCROLL = scroll compressor

(5) PHE = plates

(6) AX = axial-flow fan

Voltage: 400/3/50+N

ELECTRICAL DATA

Size	82	102	122	162	182	222	262	302
------	----	-----	-----	-----	-----	-----	-----	-----

F.L.A. - FULL LOAD CURRENT AT MAX ADMISSIBLE CONDITIONS

F.L.A. - Pump		A	1,58	1,58	1,58	1,58	2,7	2,7	2,7
F.L.A. - Total		A	24,2	28,3	32,5	37,3	43,6	60,7	68,6

F.L.I. FULL LOAD POWER INPUT AT MAX ADMISSIBLE CONDITION

F.L.I. - Pump		kW	0,82	0,82	0,82	0,82	1,45	1,45	1,45	
F.L.I. - Total		kW	13,4	15,7	18,0	21,8	25,0	29,4	33,9	37,6

M.I.C. MAXIMUM INRUSH CURRENT

M.I.C. - Value		A	78,1	115	119,2	131,9	138,9	196,0	204,1	212,0
----------------	--	---	------	-----	-------	-------	-------	-------	-------	-------

power supply 400/3/50 (+ NEUTRAL) +/- 6%

voltage unbalance: max 2 %

The pump is included in the total values calculation

for non standard voltage please contact Clivet technical office

OPERATING LIMITS (COOLING)

Size		82	102	122	162	182	222	262	302	
EXTERNAL EXCHANGER										
Max air intake temperature	1	°C	48	48,5	47	48,5	49	48,5	48,5	47,5
Max air intake temperature	2	°C	50	50,5	49	50,5	51	50,5	50,5	49,5
Min. air intake temperature	3	°C	-10	-10	-10	-10	-10	-10	-10	-10
INTERNAL EXCHANGER										
Max water inlet temperature	4	°C	23	23	23	23	23	23	23	23
Min. water outlet temperature	5	°C	5	5	5	5	5	5	5	5
Min. water outlet temperature	6	°C	-8	-8	-8	-8	-8	-8	-8	-8

Warning: the still air condition is meant as absence of air flow to the unit. Any wind condition can let air pass through the condenser coil thus worsening the operating limits of the unit (see limits with air speed at 0,5 m/s & 1 m/s).

ATTENTION: IN CASE OF PREDOMINANT WINDS, WINDBREAK BARRIERS ARE NECESSARY.

Water thermal head (min / max) are indicated in the section INTERNAL EXCHANGER PRESSURE DROP

- (1) unit at full load: internal exchanger water 12/7°C
- (2) internal exchanger water = 12/7°C capacity-controlled unit (automatic capacity control)

(3) external exchanger air in quiet

(4) this limit can be exceeded for brief and transitory periods with automatic capacity control of the unit: the maximum limit is 30°C.

capacity-controlled unit (automatic capacity control)

(5) standard unit outdoor air temperature 35°C

(6) B = Low Temperature outdoor air temperature 35°C

Fluid with ethylene glycol of 40%

CORRECTION FACTOR FOR ANTIFREEZE SOLUTIONS

% ethylene glycol by weight		5%	10%	15%	20%	25%	30%	35%	40%
Freezing temperature	°C	-2,0	-3,9	-6,5	-8,9	-11,8	-15,6	-19,0	-23,4
Safety temperature	°C	3,0	1,0	-1,0	-4,0	-6,0	-10,0	-14,0	-19,0
Cooling Capacity Factor	Nr	0,995	0,990	0,985	0,981	0,977	0,974	0,971	0,968
Compressor input Factor	Nr	0,997	0,993	0,990	0,988	0,986	0,984	0,982	0,981
Internal exchanger Glycol solution flow Factor	Nr	1,003	1,010	1,020	1,033	1,050	1,072	1,095	1,124
Pressure drop Factor	Nr	1,029	1,060	1,090	1,118	1,149	1,182	1,211	1,243

The correction factors shown refer to water and glycol ethylene mixes used to prevent the formation of frost on the exchangers in the water circuit during inactivity in winter.

FOULING CORRECTION FACTORS

m ² °C/W	INTERNAL EXCHANGER	
	F1	FK1
0.44 x 10 ⁻⁴	1,00	1,00
0.88 x 10 ⁻⁴	0,97	0,99
1.76 x 10 ⁻⁴	0,94	0,98

The cooling performance values provided in the tables are based on the external exchanger having clean plates (fouling factor 1). For different fouling factor values, multiply the performance by the coefficients shown in the table.

F1 = Cooling capacity correction factors

FK1 = Compressor power input correction factor

APPLICATION: TERMINAL UNITS

COOLING PERFORMANCES

Size	To (°C)	EXTERNAL EXCHANGER AIR INTAKE TEMPERATURE (°C)													
		25		30		32		35		40		43		46	
		kWf	kWe	kWf	kWe	kWf	kWe	kWf	kWe	kWf	kWe	kWf	kWe	kWf	kWe
82	6	26,5	6,78	25,1	7,59	24,5	7,94	23,6	8,47	22,1	9,43	21,2	10,0	20,3	10,7
	7	27,2	6,85	25,8	7,66	25,2	8,00	24,3	8,54	22,8	9,49	21,9	10,1	20,9	10,7
	9	28,7	6,98	27,2	7,79	26,6	8,13	25,7	8,66	24,1	9,60	23,2	10,2	22,2	10,8
	10	29,5	7,05	28,0	7,85	27,4	8,19	26,4	8,72	24,8	9,65	23,8	10,2	22,8	10,9
	11	30,3	7,11	28,8	7,91	28,1	8,25	27,2	8,77	25,5	9,69	24,5	10,3	23,5	10,9
	13	32,0	7,24	30,4	8,03	29,7	8,36	28,7	8,87	27,0	9,77	26,0	10,3	24,9	10,9
	16	34,7	7,43	32,9	8,20	32,2	8,52	31,1	9,01	29,3	9,85				
102	6	30,8	8,06	29,1	8,99	28,5	9,37	27,4	9,98	25,7	11,0	24,7	11,7	23,6	12,4
	7	31,6	8,15	29,9	9,06	29,3	9,45	28,2	10,0	26,5	11,1	25,4	11,8	24,3	12,4
	9	33,3	8,32	31,6	9,22	30,9	9,60	29,9	10,2	28,1	11,2	27,0	11,9	25,8	12,5
	10	34,2	8,41	32,5	9,31	31,8	9,68	30,7	10,3	28,9	11,3	27,8	11,9	26,6	12,6
	11	35,2	8,50	33,4	9,40	32,7	9,77	31,6	10,3	29,7	11,3	28,6	12,0	27,4	12,6
	13	37,1	8,69	35,3	9,58	34,5	9,94	33,4	10,5	31,5	11,5	30,3	12,1	29,1	12,7
	16	40,3	8,99	38,3	9,87	37,5	10,2	36,3	10,8	34,2	11,7				
122	6	36,5	9,92	34,9	10,8	34,2	11,2	33,0	11,8	30,8	13,0	29,4	13,9	27,8	14,8
	7	37,6	10,0	35,7	11,0	34,9	11,4	33,7	12,1	31,5	13,2	30,2	14,0	28,8	14,8
	9	39,8	10,3	37,5	11,4	36,6	11,9	35,2	12,6	33,1	13,6	31,9	14,3	30,7	14,9
	10	40,9	10,4	38,5	11,6	37,5	12,1	36,1	12,7	34,0	13,8	32,7	14,4	31,5	15,0
	11	42,0	10,5	39,5	11,7	38,5	12,2	37,1	12,9	34,9	14,0	33,6	14,6	32,3	15,2
	13	44,3	10,8	41,9	11,9	40,9	12,4	39,3	13,1	36,8	14,2	35,2	14,9		
	16	48,0	11,2	45,9	11,9	44,9	12,4	43,2	13,1	40,0	14,5				
162	6	43,7	10,9	41,3	12,1	40,4	12,7	38,9	13,4	36,4	14,8	34,8	15,7	33,2	16,5
	7	44,9	11,0	42,5	12,2	41,5	12,7	40,0	13,5	37,5	14,9	35,9	15,7	34,3	16,6
	9	47,4	11,3	44,9	12,4	43,9	12,9	42,3	13,7	39,7	15,0	38,1	15,9	36,5	16,7
	10	48,7	11,4	46,1	12,6	45,1	13,0	43,5	13,8	40,9	15,1	39,3	16,0	37,6	16,8
	11	50,0	11,5	47,4	12,7	46,4	13,2	44,8	13,9	42,1	15,2	40,5	16,1	38,8	16,9
	13	52,8	11,7	50,1	12,9	49,0	13,4	47,4	14,1	44,6	15,5	42,9	16,3	41,2	17,2
	16	57,2	12,1	54,4	13,3	53,3	13,8	51,5	14,5	48,6	15,9	46,7	16,7	44,9	17,6
182	6	50,2	13,0	47,5	14,4	46,4	15,0	44,6	15,9	41,5	17,6	39,6	18,7	37,6	19,8
	7	51,6	13,1	48,9	14,5	47,7	15,1	45,9	16,0	42,7	17,7	40,7	18,7	38,6	19,8
	9	54,6	13,3	51,7	14,7	50,5	15,3	48,6	16,2	45,1	17,8	43,0	18,8	40,7	19,9
	10	56,1	13,5	53,1	14,8	51,9	15,4	49,9	16,3	46,4	17,9	44,1	18,9	41,8	19,9
	11	57,6	13,6	54,6	14,9	53,3	15,5	51,3	16,4	47,7	18,0	45,3	19,0	42,9	20,0
	13	60,8	13,8	57,7	15,2	56,3	15,7	54,2	16,6	50,3	18,1	47,8	19,1	45,2	20,1
	16	65,9	14,3	62,5	15,6	61,0	16,1	58,7	16,9	54,4	18,4				
222	6	59,1	15,7	56,1	17,4	54,8	18,1	52,9	19,2	49,5	21,2	47,3	22,5	45,1	23,8
	7	60,7	15,9	57,6	17,5	56,3	18,2	54,4	19,4	50,9	21,3	48,8	22,6	46,6	23,9
	9	64,1	16,2	60,8	17,8	59,5	18,5	57,5	19,7	54,0	21,6	51,9	22,9	49,7	24,2
	10	65,8	16,3	62,5	18,0	61,1	18,7	59,1	19,8	55,6	21,7	53,5	23,0	51,3	24,3
	11	67,5	16,5	64,2	18,1	62,8	18,8	60,7	19,9	57,2	21,9	55,1	23,1	52,9	24,4
	13	71,1	16,8	67,7	18,5	66,3	19,1	64,2	20,2	60,6	22,1	58,4	23,3	56,3	24,5
	16	76,6	17,2	73,1	18,9	71,7	19,6								

To = Internal exchanger water outlet temperature in °C
 kWf = Cooling capacity in kW
 kWe = Compressor power input in kW
 Performances in function of the inlet/outlet water temperature differential = 5°C

E107F01ZCE09

APPLICATION: TERMINAL UNITS

COOLING PERFORMANCES

Size	To (°C)	EXTERNAL EXCHANGER AIR INTAKE TEMPERATURE (°C)													
		25		30		32		35		40		43		46	
		kWf	kWe	kWf	kWe	kWf	kWe	kWf	kWe	kWf	kWe	kWf	kWe	kWf	kWe
262	6	69,7	18,1	66,1	20,0	64,7	20,8	62,3	22,1	58,2	24,4	55,7	25,8	53,0	27,4
	7	71,6	18,3	68,0	20,2	66,5	21,0	64,1	22,3	60,0	24,5	57,4	26,0	54,7	27,5
	9	75,6	18,6	71,8	20,5	70,2	21,3	67,7	22,6	63,5	24,8	60,9	26,2	58,2	27,7
	10	77,6	18,8	73,7	20,7	72,1	21,5	69,6	22,7	65,3	24,9	62,7	26,3	60,1	27,8
	11	79,7	18,9	75,6	20,8	74,0	21,6	71,5	22,9	67,2	25,1	64,6	26,4	62,0	27,9
	13	84,0	19,2	79,7	21,1	77,9	21,9	75,4	23,2	71,1	25,3	68,5	26,6	66,0	28,0
	16	90,6	19,6	85,9	21,6	84,1	22,4	81,5	23,6	77,2	25,6				
302	6	78,4	20,8	74,5	22,9	72,8	23,9	70,3	25,3	65,8	28,0	63,0	29,6	60,0	31,4
	7	80,6	21,0	76,5	23,2	74,8	24,1	72,2	25,5	67,7	28,2	64,9	29,8	62,0	31,6
	9	84,9	21,4	80,7	23,6	79,0	24,5	76,4	25,9	71,8	28,6	69,0	30,2	66,1	32,0
	10	87,1	21,6	82,9	23,8	81,2	24,7	78,5	26,1	74,0	28,8	71,2	30,4	68,3	32,2
	11	89,4	21,8	85,1	24,0	83,4	24,9	80,7	26,3	76,2	28,9	73,5	30,6	70,7	32,3
	13	94,0	22,2	89,6	24,4	87,9	25,3	85,3	26,7	80,9	29,3	78,3	30,9	75,7	32,6
	16	101,0	22,8	96,8	25,0	95,1	25,9	92,6	27,3	88,6	29,7				

To = Internal exchanger water outlet temperature in° C
 kWf = Cooling capacity in kW
 kWe = Compressor power input in kW
 Performances in function of the inlet/outlet water temperature differential = 5°C

ACCESSORIES

Each accessory is marked by a configuration code, e.g. CMMBX.

If the last letter is X, it means that the accessory is provided separately. If the code does not contain the letter X, the accessory is installed at the factory.

(SFSTR4N)disposal for inrush current reduction, for unit 400/3/50+N

Starting up a motor directly can overload the electricity network, with start-up currents up to 8 times the nominal current. Thanks to the breakaway current reduction device, start-up takes place gradually, with the start-up current being limited during this period of time.

The start-up current can therefore be reduced to 3.5 - 4 times the nominal current, meaning that the power systems and protection devices can be sized with lower parameters.

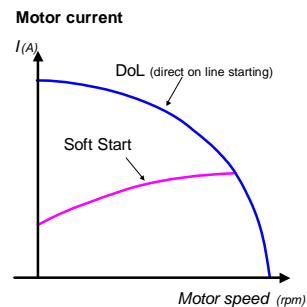

optional accessory

(CMMBX)serial communication module to supervisor (MODBUS)

The serial communication module to supervisor (MODBUS) is connected with the principal module through a comb connection (see lay-out on electrical panel). In this way the remote assistance and supervision are available through standard MODBUS protocol.

It is possible to connect to a single supervisor system up to 127 units.

The connection to PC must be obtained through a converter RS485/232; the serial port RS232 admits as maximum a 10 m length. The serial communication module to supervisor (MODBUS) is necessary when the unit is connected to ELFOCONTROL.

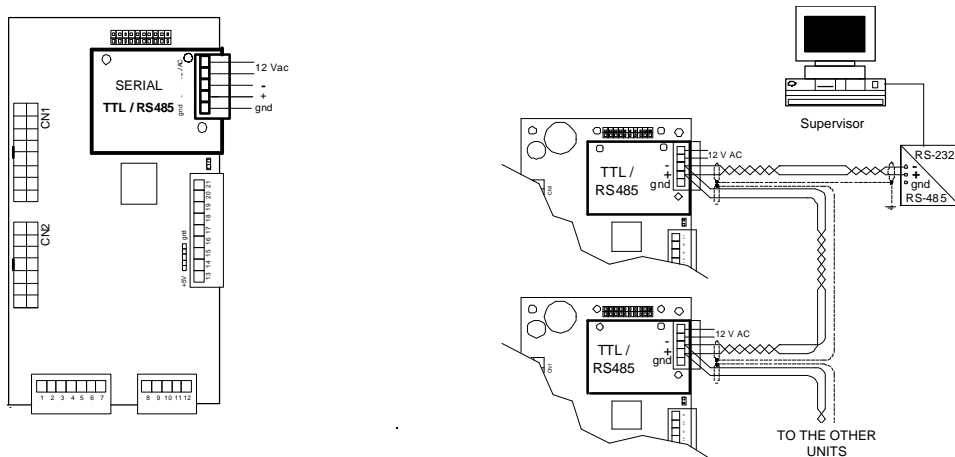

separately supplied accessories

(SCP3X)Set point compensation with according to outdoor enthalpy

It allows to modulate unit set-point according to the external enthalpy. In this way an higher comfort and continuous energy saving are guaranteed. It optimizes unit energy efficiency, through a set point automatic modulation, according to the external conditions (temperature + humidity).

It optimiezs also the defrosting time during winter operation.



separately supplied accessories

(PMX)phase monitor

phase monitor to check the presence and correct sequence of the power supply phases.



separately supplied accessories

E107F014CE09

(-)unit without hydronic assembly

The unit can be requested without circulating pump, safety valve water side and filling assembly.

separately supplied accessories

(1PUR)Single pump with reduced working head

Accessories not available in Free-Cooling units

CURVE OF DISCHARGE HEAD WITH REDUCED PUMP (PUMP + WATER FILTER)

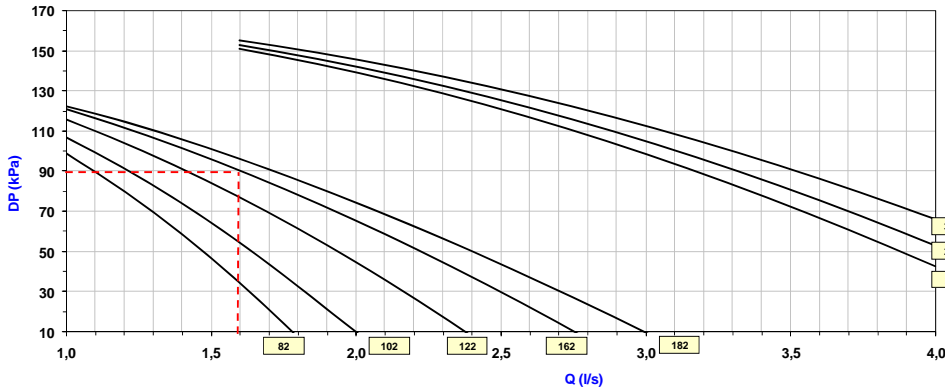

THE HEADS ARE INTENDED AS AVAILABLE AT THE UNIT CONNECTIONS
Q[L/S]= WATER-FLOW RATE
DP[KPA]=USEFUL DISCHARGE HEAD

optional accessory

(1PUM)Single pump with increased working head

Accessories not available in Free-Cooling units

CURVE OF DISCHARGE HEAD WITH LARGER PUMP (PUMP + WATER FILTER)

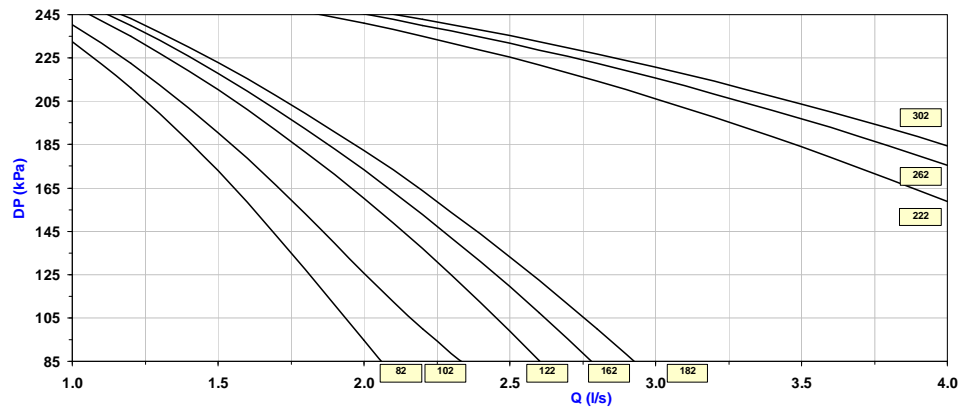

THE HEADS ARE INTENDED AS AVAILABLE AT THE UNIT CONNECTIONS
Q[L/S]= WATER-FLOW RATE
DP[KPA]=USEFUL DISCHARGE HEAD

optional accessory

(2PUS)standard double pump

Accessories not available in Free-Cooling units 82-102

DOUBLE PIMP PRESSURE DROP CURVES

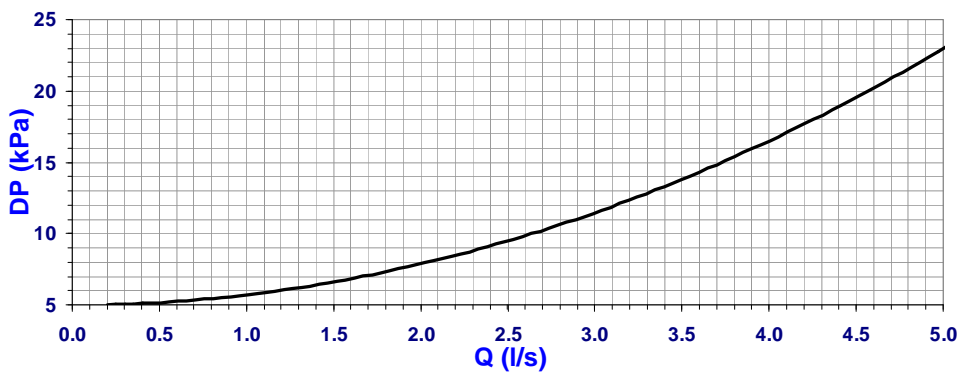

Q[L/S]= WATER-FLOW RATE
DP = PRESSURE DROP
PRESSURE DROP TO REMOVE IN THE ACCESSORY SELECTION: DOUBLE PUMP. BOTH PUMPS CAN HAVE A STANDARD, REDUCED OR LARGER AVAILABLE HEAD. THE SECOND PUMP STARTS UP AUTOMATICALLY IN CASE OF THE FIRST PUMP FAILURE. THE UNIT CONTROL ALLOWS AN OPERATION ROTATION OF BOTH PUMPS. THE AVAILABLE HEAD, IN CASE OF THE DOUBLE PUMP USE, IS THE AVAILABLE HEAD OF THE SINGLE CHOSEN PUMP (STANDARD, REDUCED OR LARGER) LESS THE PRESSURE DROPS AS YOU CAN SEE FROM THE GRAPH.

optional accessory

B107F014CB09

(2PUR)Double pump with reduced working head

Accessories not available in the units 82-102-122 and in the Free-Cooling units

optional accessory

(2PUM)Double pump with increased working head

Accessories not available in Free-Cooling units

optional accessory

(D)Energy recovery

partial recovery of condensing heat, up to 25%

The use of a desuperheater in a system developed based on the maximum energy efficiency and with a request for hot water, is practically an obligatory choice because it makes it possible to recover, free of charge, the heat that would otherwise be dispersed in the environment. The partial heat recovery is composed of shell and tube heat exchangers suitable for recovery of 25% of the heat power dispersed by the unit (cooling and electrical power of the compressors). With the desuperheater active, the performance of the unit improves since the condensation temperature is lowered. Approximately, the cooling power increases by 3.2% and the power absorbed by the compressors decreases by 3.6%. If the temperature of the water to be heated is relatively low, it is advisable to insert in the plumbing circuit an adjustment valve to keep the recovery inlet temperature greater than 35° C to prevent condensation.

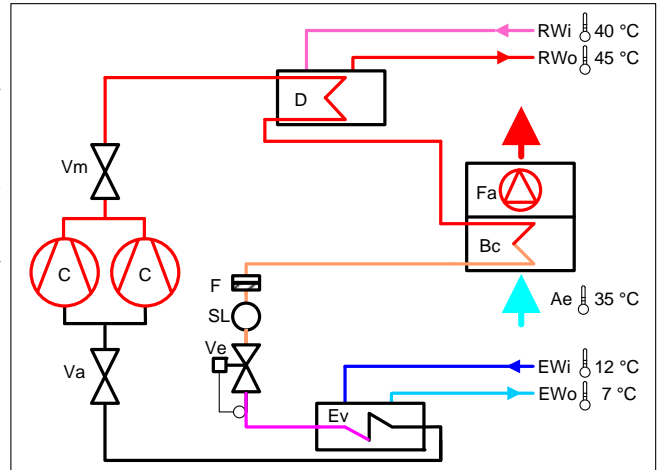

Legend
Ae = fresh air
Bc = condensing coil
C = compressor
D = partial heat recovery
Ev = evaporator
EWi = chilled water inlet
EWO = chilled water outlet

F = dryer filter
Fa = fan
RWi = partial recovery water inlet
RWO = partial recovery water outlet
SL = liquid indicator
Ve = expansion valve
VA = bibcock on the suction line
Vm = bibcock on supply line

optional accessory

(CLS)free contacts for external signalling

Free contacts for compressor status

optional accessory

(PFCP)power factor correction capacitors (cosfi > 0.9)

the resetting condensers increase the power factor value, reducing the apparent current on the supply line to the chiller assembly



optional accessory

(RCMRX)Remote control with remote microprocessor control

Accessories not available in Free-Cooling units

the remote control allows the remote display and operation of functions of the microprocessor on the unit

separately supplied accessories

(SPCX)set point compensation with outside temperature probe

Set point compensation by air temperature probe varies the value of the set point according to the outside air temperature, allowing energy savings



separately supplied accessories

E107F0141CE-09

(ACC1)Storage

Accessories not available in Free-Cooling units

Inertial storage tank of 80 litres, for applications where the system has limited water content.
(sizes 82-102-122)
Inertial storage tank of 120 litres, for applications where the system has limited water content.
(sizes 162-182-222-262-302)

optional accessory

(IFWX)Steel mesh filter on the water side

stainless steel mesh mechanical filter (to be used, if required, with unit configured without hydronic group)
steel mesh mechanical filter positioned at the exchanger inlet. Suitable for filtering water and trapping the impurities present in the water circuit.

separately supplied accessories

(AMRX)Rubber antivibration mounts

The rubber antivibration mounts reduce the vibrations of compressor during its operation and they are installed at the base feet.

separately supplied accessories

(CCCA)copper / aluminium condenser coils with acrylic lining

The copper/aluminium evaporator coils with acrylic lining can be used in the room where the ambient air contains a concentration of salt and other not very aggressive agents.

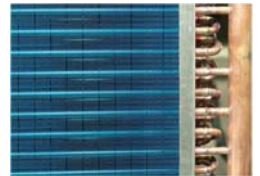

optional accessory

(CCCA1)copper / aluminium condenser coils with Fin Guard (Silver) treatment

The Fin Guard Silver, for finned exchanger, is a polyurethane vernish waterproof (for waterworks, see and discharge water). It is also resistant to oil products and other different solvents. It hasn't any effects on the air side pressure drops.



optional accessory

(PGCEX)finned coil protection grill.

The protection battery pack grilles , protect fins from accidental bumps.



separately supplied accessories

E107F014CB09

(FCD)WSAT-XEE Free-Cooling

ATTENTION:

The unit WSAT-XEE 122 in Free-Cooling version, is built on mobile sizes 162-182, the same for the size 222, that is developed on Movable 262-302.

The weights of the units vary in reference to what is present in this document.

FREE-COOLING When the temperature of the fresh air is lower than the temperature of the return water of the system, the free-cooling version lets you recover cold from the external environment, reducing the work of the compressors all the way down to nothing. IT IS INTENDED for all applications that require chilled water even in cold weather, such as industrial processes, data processing centres, telephone plants, shopping centres, etc.



USE OF ANTI-FREEZE SOLUTIONS

The heat carrier used in the systems that include a Free-Cooling device require a glycol solution (usually an ethylene type). This substance is required because the Free-Cooling units are intended to be installed where the temperature can drop to very low levels during certain times of the year. The percentage of glycol in the solution depends on the low temperatures that can be expected in the place of installation. Therefore, this parameter is at the discretion of the system designer.

OPERATING LOGIC OF CLIVE UNITS

The Free-Cooling unit differs mechanically from the standard unit due to the addition of a 3-way valve and a special finned packaged air/water heat exchanger. Seasonal weather conditions cause the unit to operate in one of three different modes:

- Summer mode.
- Spring/autumn mode.
- Winter mode.

For the unit to work correctly in all situations, in complete safety, and with complete recovery of cooling power, the use of a modern, sophisticated microprocessor is required, which monitors a number of parameters (especially temperature and pressure) for the fresh air, gas and water circuit.

The main difference between summer mode and the other modes is the position of the 3-way valve.

In the summer, the valve is positioned so that it bypasses the Free Cooling coils, which in the other seasons are involved in cooling the solution.

OPERATING LOGIC IN SUMMER MODE

- cooling of the solution is ensured by the refrigerating cycle with operation of the compressors (C) as in a traditional chiller - as you can see in the figure, the Free-Cooling (Bh) coils are not involved.

- Legend
- Ae = fresh air
 - Bc = condensing coil
 - Bh = water coil
 - C = scroll compressor
 - Ev = plate evaporator
 - F = filter dryer

- Fa = fan
- SL = liquid waring light
- V3 = three-way valve
- Ve = expansion valve
- VA = cock on the suction line
- Vm = cock on the return line
- Wi = water inlet
- Wo = water outlet

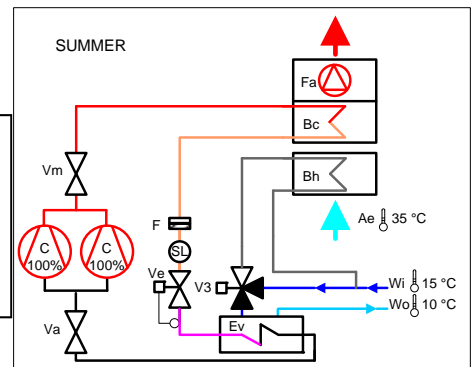

OPERATING LOGIC IN SPRING/AUTUMN MODE

- energy savings variable between 0 and 100%, based on the temperature difference between fresh air and the system request;

- if the unit detects that the fresh air temperature (Ae) is suitable:

- 1) it inverts the position of the 3-way valve (V3), forcing the solution to travel through the Free-Cooling coils (Bh) before reaching the evaporator (Ev);
- 2) it sets the fans (Fa) at maximum speed to obtain maximum cooling of the solution from the fresh air;
- 3) the solution thus undergoes an initial cooling which is free and natural;
- 4) the remaining cooling is provided by the refrigeration cycle, with compressors in stepped operation (power absorbed proportional to the degree of stepping);

- if the temperature of fresh air increases, the microprocessor will automatically revert operation to summer mode, ensuring the same conditions requested by the user.

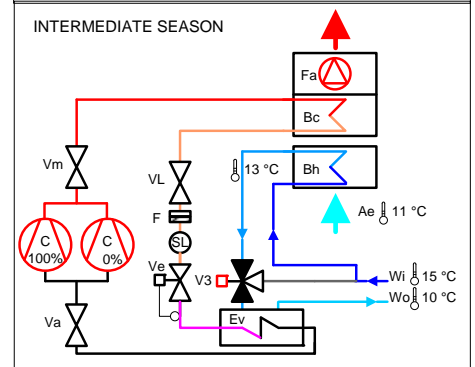

OPERATING LOGIC IN WINTER MODE

the three way valve (V3) is in the same position as in the previous case;

- the temperature of the fresh brings the solution at the outlet of the Free-Cooling coils (Bh) to the temperature required for use;

- the microprocessor control completely deactivates all compressors (C), providing all cooling power at no cost, as opposed to standard units;

- if the difference between the temperature of the fresh air (Ae) and that required for use is such that the temperature of the solution at the outlet of the Free-Cooling coils (Bh) drops below the set point required for use (which does not compromise unit safety, because of the glycol in the solution), the microprocessor modulates fan speed (Fa), turning them off if necessary. When the fans are off, if the temperature (Wo) continues to drop, the 3-way valve (V3) positions itself as in summer operation, changing to digital and allowing the set point to be maintained.

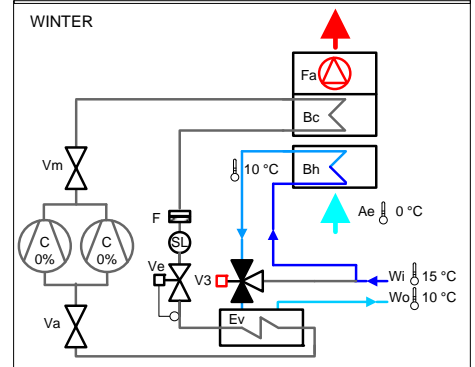

DETERMINATION OF CHILLER PERFORMANCE WITH FREE-COOLING IN CONDITIONS OF FC = OFF

The performance of a unit provided with a free-cooling device varies with respect to the information provided for the standard units as shown in the table:

Glicole	10%	20%	30%	40%
Potenza Frigorifera	0.97	0.96	0.95	0.94
Potenza assorbita compressori	1.040	1.034	1.030	1.027

EXAMPLE:

Determine the performance of a unit WSAT-XEE 82, free-cooling with water 12/7 °C (30% gl) and fresh air 35°C.

WSAT-XEE 82
Cooling power = 24.3 Kw
Electrical power of compressors = 8.5 kw

WSAT-XEE FC 82
Cooling power = 24.3 x 0.95 = 23.1 kW
Electrical power of compressors = 8.5 x 1.03 = 8.75 kw

DETERMINATION OF CHILLER PERFORMANCE WITH FREE-COOLING IN CONDITIONS OF FC = ON

Size		82	102	122	162	182	222	262	302
Free-Cooling nominal capacity (1)	Kw	25,1	29,2	34,3	41,4	47,4	66,2	74,6	78,8
Air temperature with Free-Cooling at 100% (1)	Kw	-1,0	-3,0	0,0	-2,0	-3,0	-2,0	-3,0	-4,5

(1) Data referred to the following conditions :

- Water temperature IN-OUT 15/10°C;
- Percentage of glycol 30%;

DETERMINATION OF FREE-COOLING PERCENTAGE

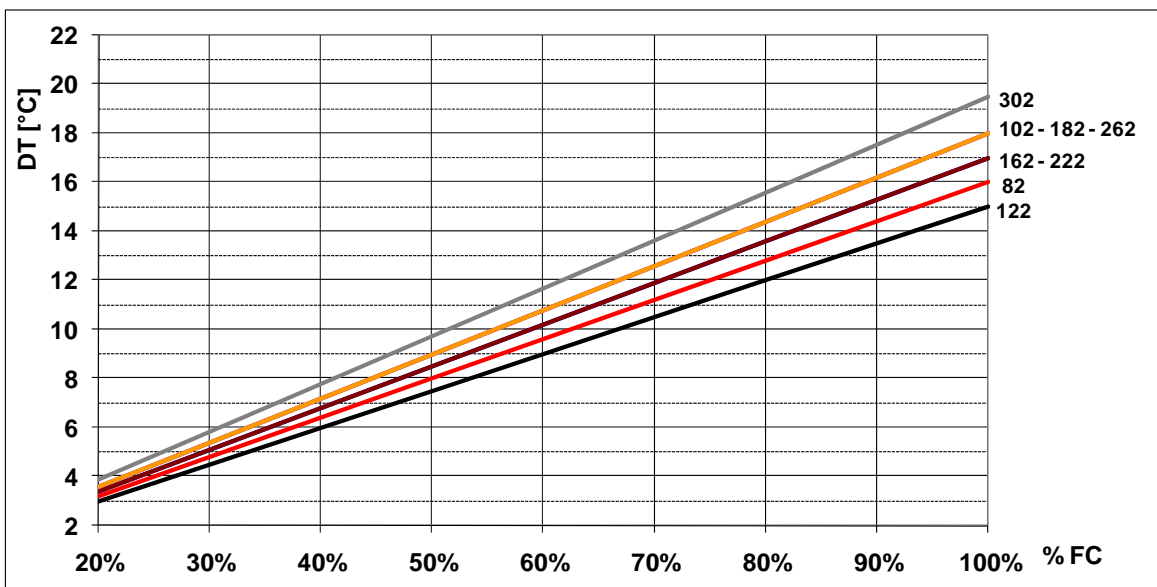

% FC = percentage with respect to nominal potential of Free-Cooling (water = 15/10°C, 30% gl)

DT = temperature difference between return water from system and fresh air.

EXAMPLE:

Determine the FC performance for a WSAT-XEE 82 unit with water 12/7 °C - 30% gl and fresh air 1 °C.

Nominal power of FC = 25.1 kW with H2O = 15/10 °C - 30% gl, fresh air -1 °C.

Temperature differential = 12°C - 1 °C = 13°C

Percentage of nominal Fc = 81%

FC power with fresh air at 1°C = 25.1x0.81 = 20.3 kW.

INTERNAL EXCHANGER PRESSURE DROPS + COILS + 3-WAY VALVE

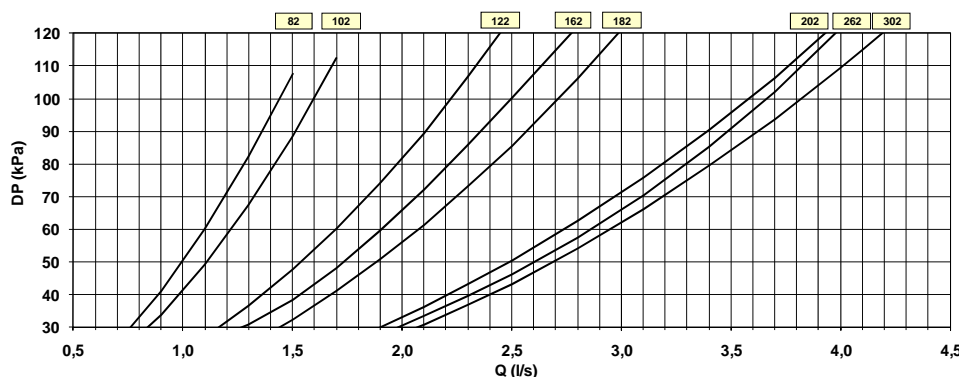

UNIT WITHOUT PUMP
Q = WATER FLOW-RATE
DP = PRESSURE DROPS

B107F014CB09

(CREFB)ECOBreeze

Within the range of air condensation-based products, Clivet introduces an innovative technology based on the deployment of fans driven by Brushless motors, completely electronically-controlled, characterised by extremely high efficiency and which allow a very advanced adjustment of fan speeds.

The ECOBreeze option envisages the utilisation of special fans driven by electrical Brushless motors. This technology envisages a permanent-magnets rotor, coupled with a very advanced magnetic field electronic switching control to the stator, directly integrated within the motor itself.

A veritable "feather in the cap" is the electronic switching device that manages the precise and effective modulation of the fan's rotation speed and, therefore, of the fan's capacity. The management of this device is entrusted to the unit's general control system, thus assuring complete integration with the other refrigerating unit's components; this also allows the attaining of an exceptional overall efficiency. Furthermore, by integrating the control directly within the fan, one is guaranteed absolute suitability in the regulator/fan pair, differently from what is experienced in traditional systems.

Finally, under particularly demanding or emergency conditions, for example should the environment temperature rise beyond the limits foreseen, before shutting the delivered power and/or setting the unit under alarm, the control device will detect the specific situation and will force the fans to a rotation speed beyond the nominal value, thus assuring an additional capacity of about 15% of the specified value. In this way, it is possible to assure the production of refrigerated water also when traditional units would be forced into alarm conditions.



Electric motor intrinsic efficiency guarantees a consumption reduction in every operation conditions.

The final result confirms that in comparison to the traditional three-phase induction motors, also with frequency and/or voltage governing, the internal losses within the iron are reduced by 60%, those of the copper by 40%, whereas the intrinsic consumption is about half of that of a traditional modulator (inverter, phase adjuster). The energy cutback, and therefore the money saved, under all operating conditions are truly remarkable and the initial investment is repaid in very few months. From that moment onwards the reduced operative costs turn directly into an economic gain for the user.

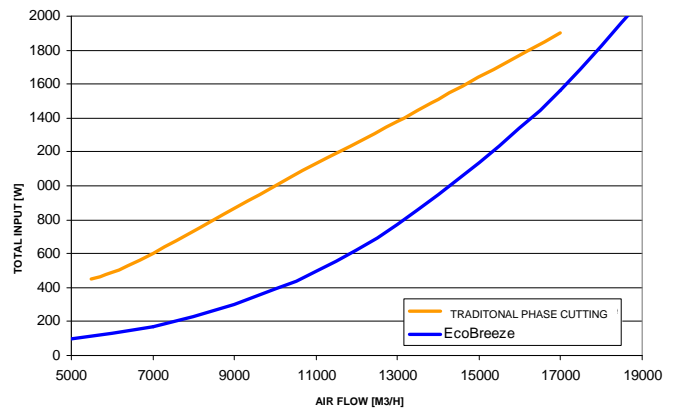
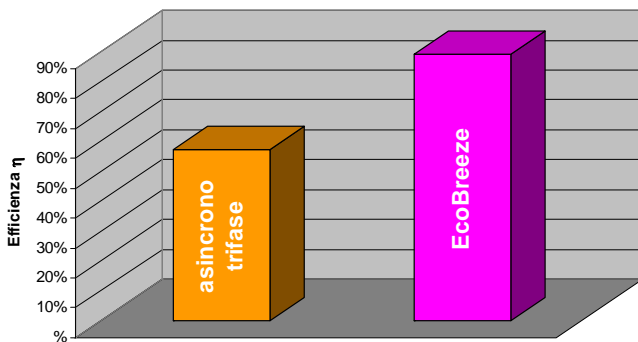

When fans turn at minimum necessary speed, noise emissions are reduced.

In addition to this, a generalised reduction in noise emission is obtained, due to the effect of both the rotation speed which is always modulated to the most suitable value, in keeping with the operation conditions, and the technology deployed in the governing which doesn't induce particular frequencies and vibrations in the rotation.

The start-up is progressive, without start absorption peaks.

The current damping at start-up (see diagram) due to the control typology, but also to the absence of brushing contacts for the power supply to the rotor, drastically reduce the harmful stresses for the lifetime of the component. In the final analysis, the fan's life can be considered as practically unlimited (greater than 80,000 hours).

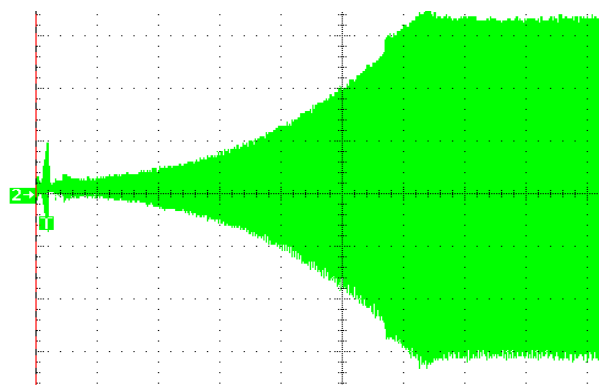
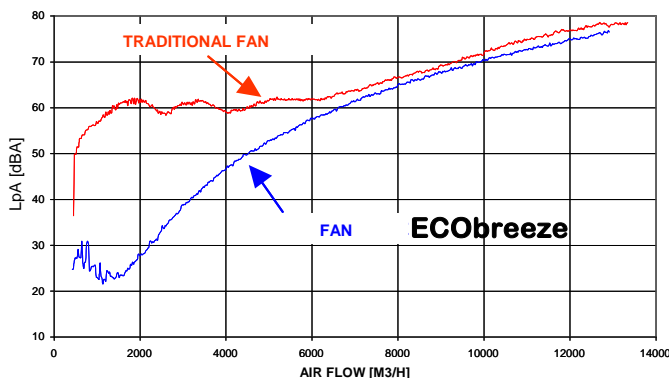

DIMENSIONAL DRAWINGS

DIMENSIONALS AND WEIGHT DISTRIBUTION WSAT-XEE 82-102-122

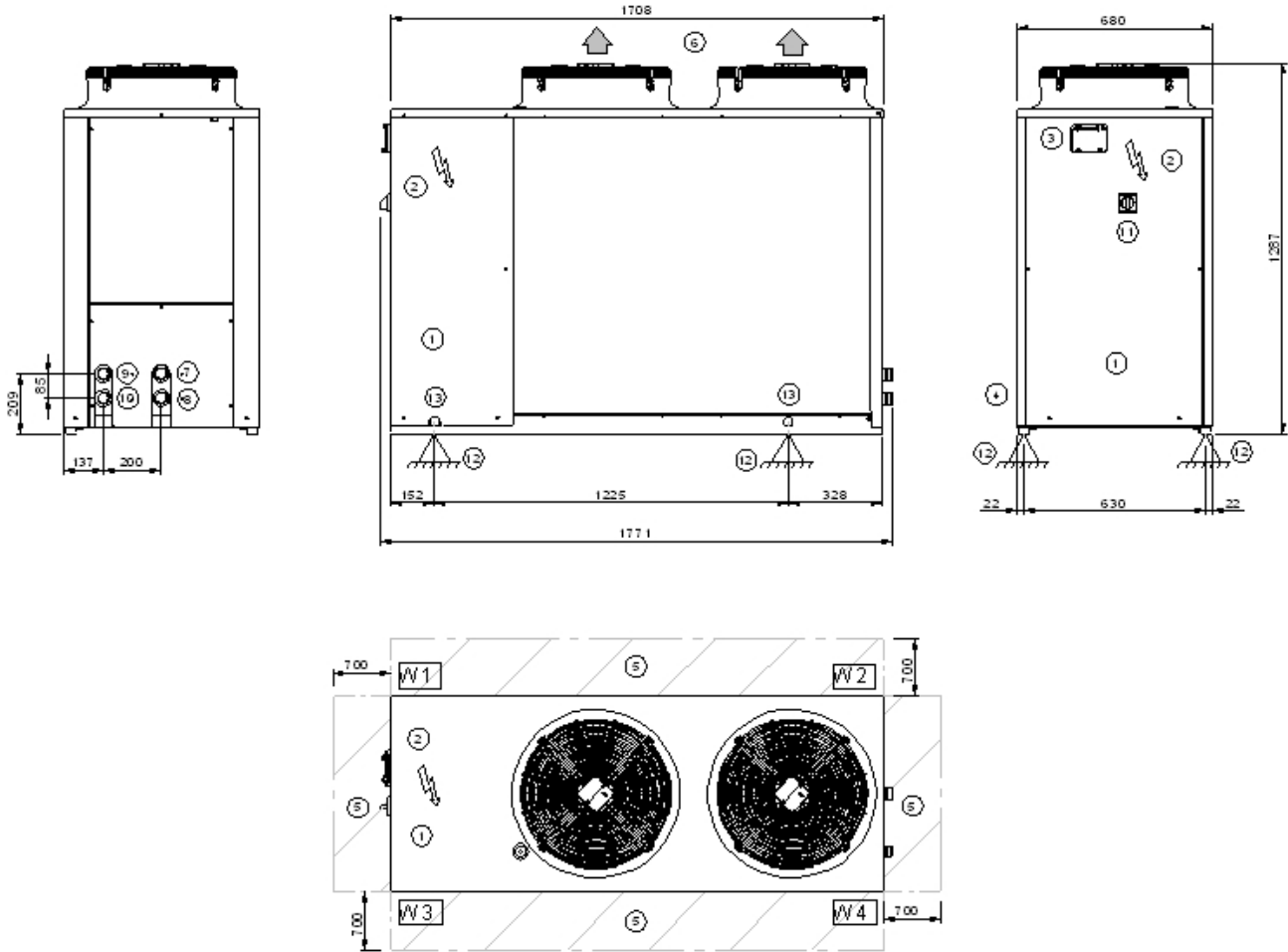

- (1) COMPRESSOR COMPARTMENT
- (2) ELECTRICAL PANEL
- (3) KEYBOARD CONTROL UNIT
- (4) POWER INPUT
- (5) FUNCTIONAL SPACE
- (6) AIR SUPPLY
- (7) WATER INLET 1 1/4" VICTAULIC
- (8) WATER OUTLET 1 1/4" VICTAULIC
- (9) DESUPERHEATER WATER INLET 1" 1/4 VICTAULIC (OPTIONAL)
- (10) DESUPERHEATER WATER OUTLET 1" 1/4 VICTAULIC (OPTIONAL)
- (11) MAIN ISOLATOR SWITCH
- (12) VIBRATION MOUNTS POSITION
- (13) LIFTING HOLES POSITION

SIZES		STANDARD			FREE-COOLING	
		82	102	122	82	102
M	mm	599	598	587	613	611
N	mm	843	842	838	784	786
O	mm	289	289	283	260	260
P	mm	337	336	333	337	336
Length	mm	1771	1771	1771	1771	1771
Depth	mm	680	680	680	680	680
Height	mm	1287	1287	1287	1287	1287
W1	kg	83	85	90	89	90
W2	kg	54	55	57	66	66
W3	kg	98	100	107	118	119
W4	kg	63	64	68	86	87
Operating weight	kg	298	303	323	359	362
Shipping weight	kg	304	309	328	348	351

OPTIONAL ACCESSORIES MAY RESULT IN A SUBSTANTIAL VARIATION OF THE WEIGHT SHOW IN TABLE

DIMENSIONAL DRAWINGS

DIMENSIONALS AND WEIGHT DISTRIBUTION WSAT-XEE 162-182-222

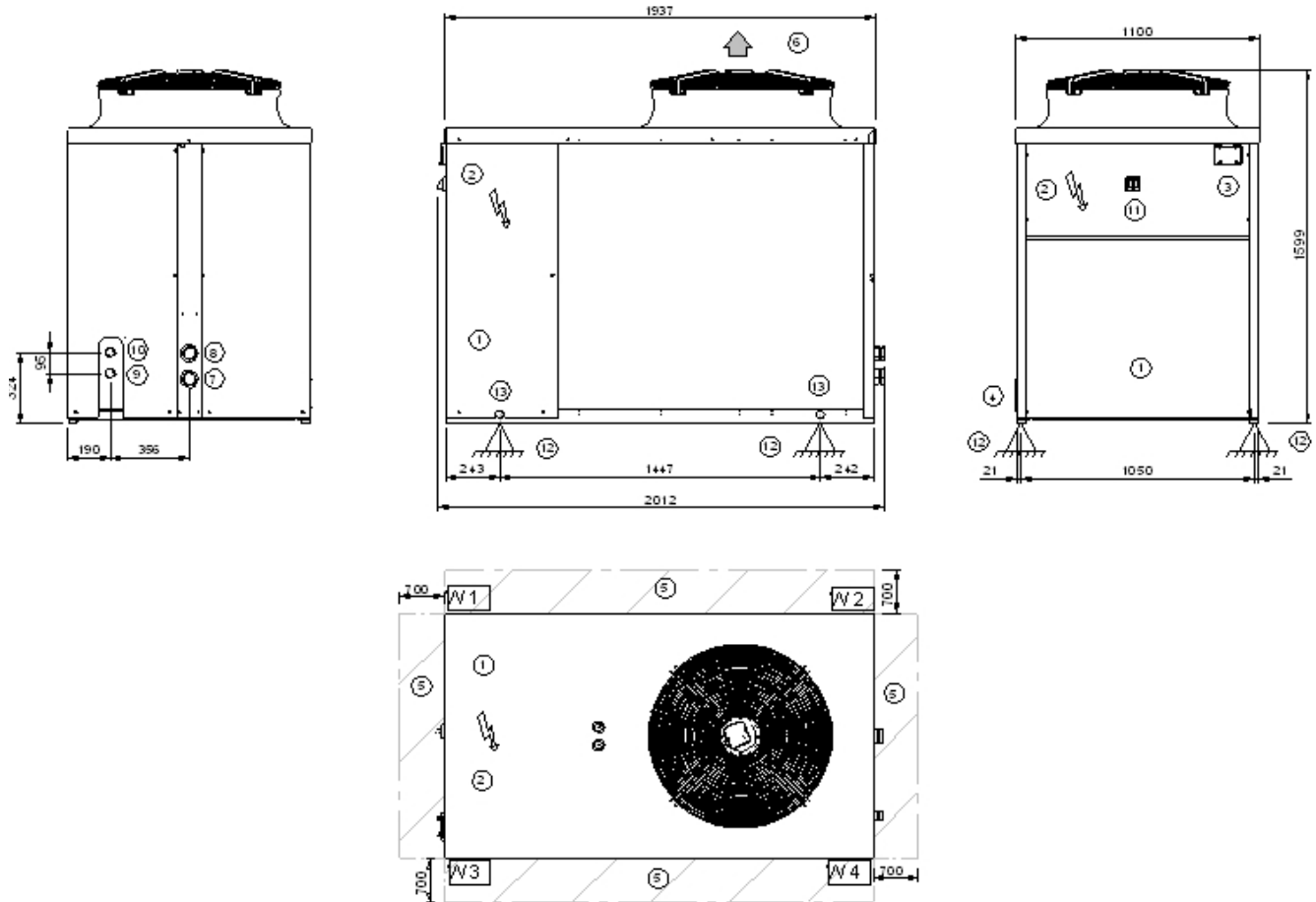

- (1) COMPRESSOR COMPARTMENT
- (2) ELECTRICAL PANEL
- (3) KEYBOARD CONTROL UNIT
- (4) POWER INPUT
- (5) FUNCTIONAL SPACE
- (6) AIR SUPPLY
- (7) WATER INLET 2" VICTAULIC
- (8) WATER OUTLET 2" VICTAULIC
- (9) DESUPERHEATER WATER INLET 1" 1/4 VICTAULIC (OPTIONAL)
- (10) DESUPERHEATER WATER OUTLET 1" 1/4 VICTAULIC (OPTIONAL)
- (11) MAIN ISOLATOR SWITCH
- (12) VIBRATION MOUNTS POSITION
- (13) LIFTING HOLES POSITION

SIZE			STANDARD			FREE-COOLING	
			162	182	222	122	162
M	mm	678	675	700	759	706	705
N	mm	1183	1180	1139	1030	1096	1099
O	mm	466	460	442	422	422	423
P	mm	566	566	571	549	559	560
Length	mm	2012	2012	2012	2012	2012	2012
Depth	mm	1100	1100	1100	1100	1100	1100
Height	mm	1599	1599	1599	1599	1599	1599
W1	kg	140	143	141	132	154	156
W2	kg	65	66	72	87	84	85
W3	kg	172	178	184	174	206	209
W4	kg	79	82	94	114	112	113
Operating weight	kg	456	469	490	507	556	563
Shipping weight	kg	464	476	497	493	542	548

OPTIONAL ACCESSORIES MAY RESULT IN A SUBSTANTIAL VARIATION OF THE WEIGHT SHOW IN TABLE

E107F01ACE09

DIMENSIONAL DRAWINGS

DIMENSIONALS AND WEIGHT DISTRIBUTION WSAT-XEE 262-302

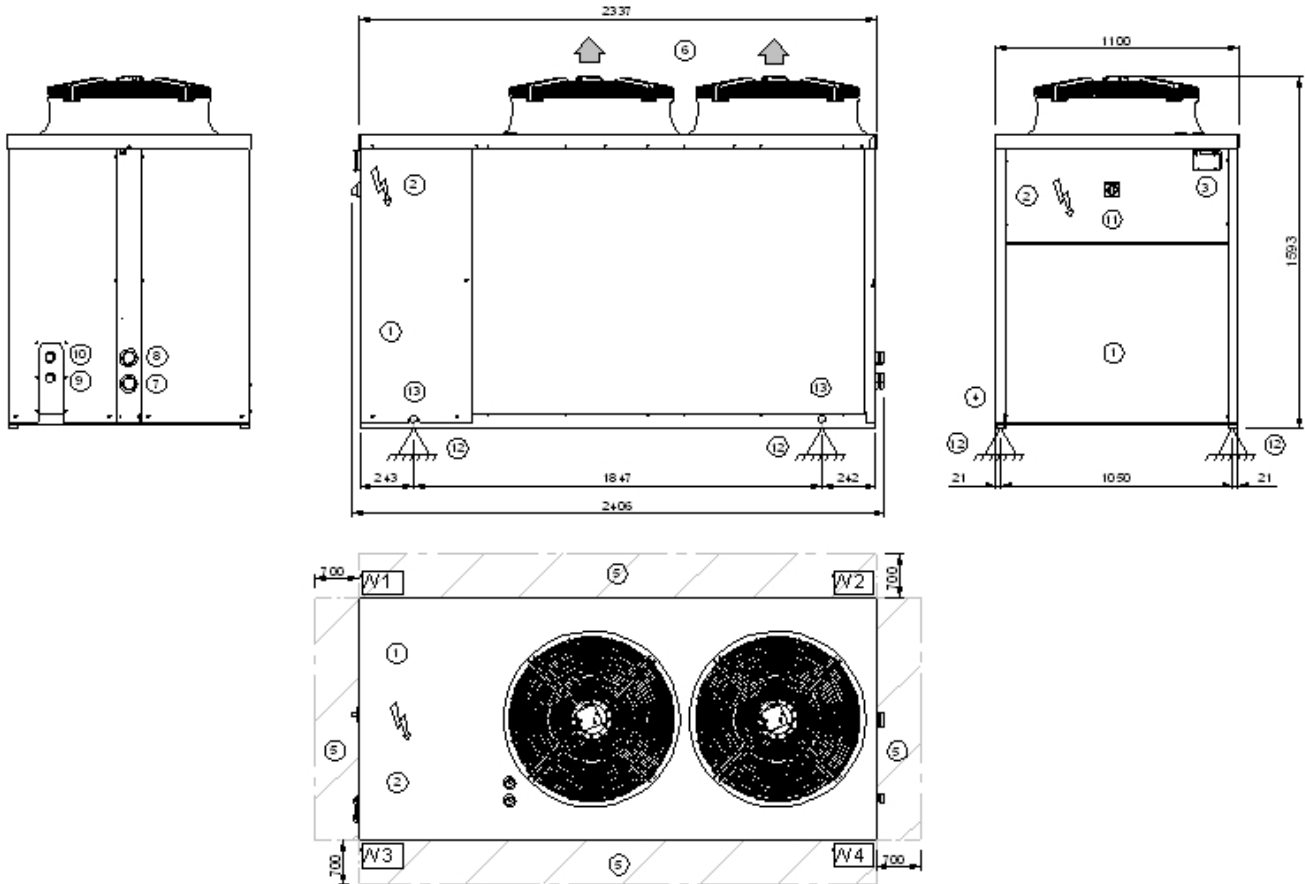

- (1) COMPRESSOR COMPARTMENT
- (2) ELECTRICAL PANEL
- (3) KEYBOARD CONTROL UNIT
- (4) POWER INPUT
- (5) FUNCTIONAL SPACE
- (6) AIR SUPPLY
- (7) WATER INLET 2" VICTAULIC
- (8) WATER OUTLET 2" VICTAULIC
- (9) DESUPERHEATER WATER INLET 1" 1/4 VICTAULIC (OPTIONAL)
- (10) DESUPERHEATER WATER OUTLET 1" 1/4 VICTAULIC (OPTIONAL)
- (11) MAIN ISOLATOR SWITCH
- (12) VIBRATION MOUNTS POSITION
- (13) LIFTING HOLES POSITION

SIZE		STANDARD			FREE-COOLING	
		262	302	222	262	302
M	mm	865	862	654	671	677
N	mm	1143	1138	1062	1036	1038
O	mm	429	426	410	405	408
P	mm	596	593	564	572	571
Length	mm	2406	2406	2406	2406	2406
Depth	mm	1100	1100	1100	1100	1100
Height	mm	1593	1593	1593	1593	1593
W1	kg	134	138	154	150	153
W2	kg	93	95	119	126	127
W3	kg	189	194	215	215	217
W4	kg	131	138	166	180	181
Operating weight	kg	547	561	654	671	677
Shipping weight	kg	556	569	633	649	654

OPTIONAL ACCESSORIES MAY RESULT IN A SUBSTANTIAL VARIATION OF THE WEIGHT SHOW IN TABLE

BLANK PAGE

CLIVET SPA
Feltre (BL) - Italy
Tel. + 39 0439 3131
Fax + 39 0439 313300
info@clivet.it

CLIVET UK LTD
Fareham, Hampshire -
UK United Kingdom
Tel. + 44 (0) 1489
572238 Fax + 44 (0)
1489 573033 in-
fo@clivet-uk.co.uk

CLIVET SAS
France
Tel. + 33 (0)1 69202575
Fax + 33 (0)1 69206076
info.fr@clivet.com

CLIVET ESPAÑA S.A.
Madrid - España
Tel. + 34 91 6658280
Fax + 34 91 6657806
info@clivet.es

CLIVET GmbH
Norderstedt - Germany
Tel. + 49 (0) 40 32 59 57-0
Fax + 49 (0) 40 32 59 57-194
info.de@clivet.com

CLIVET NEDERLAND B.V.
Amersfoort - Netherlands
Tel. + 31 (0) 33 7503420
Fax + 31 (0) 33 7503424
info@clivet.nl

CLIVET RUSSIA
Moscow, Russia
Tel. + 74956462009
Fax + 74956462009
info.ru@clivet.com

CLIVET MIDEAST FZC
Dubai Silicon Oasis -
Dubai, UAE
Tel. + 97 14 3208499
Fax + 97 14 3208216
info@clivetme.com

**CLIVET
AIRCONDITIONING
SYSTEMS (P) LTD**
Mumbai 400 072 (INDIA)
Tel + 91 - 22 - 6193 7000
Fax + 91 - 22 - 6193 7001
sales.india@clivet.com